



FULL-BODY RACE

Assembly Instructions

FR-000RC2

SHOULDER RACE INSTRUCTIONS ON INSIDE

Osborne FIRE Feeders are packaged carefully and compactly to ensure their safe arrival. Each part was quality inspected prior to shipment and each carton was carefully packed to ensure that all necessary parts were present for the assembly.

NOTICE

All loss or damage in transit is the responsibility of the delivering carrier, NOT OSBORNE INDUSTRIES. To protect your rights in the event of damage or loss, sign the delivery waybill only after the carrier has acknowledged in writing that damage or loss has occurred. In the event that damage is revealed only after unpacking is complete, notify the delivering carrier immediately and request an inspection of the damaged merchandise before proceeding.

Before attempting the assembly process, identify all parts with the Parts List at the right. Once all parts have been identified, inspected for freight damage, and counted, proceed to assembly.

Osborne FIRE® Feeder Full-Body Race		
Part Number	Description	Qty
KR-FRL100	Long Race End	1
KR-FRL110	Long Race Bar	1
KR-FRL130	FIRE Race Drop Pin	4
KR-FRL300	FIRE Long Race Panel	2
SR-FFD102	Race Adjust Angle	2
KR-FRL200	Bolt Kit	
RFB-2050	Bolt, 5/16 x 7/8-in.	8
RFN-2100	Hex Nut, 5/16-in.	8
RFW-2300	Lock Washer, 5/16-in.	8
RFB-2150	Bolt, 5/16 x 1 1/2-in.	2
RLX-0914	Assembly Instructions	1

Required Tools	
1/2-in. wrench	1/2-in. socket with ratchet

ASSEMBLY INSTRUCTIONS:

1. Remove the small black access panel from the front of the FIRE Feeder and remove the packaged IFC enclosure.

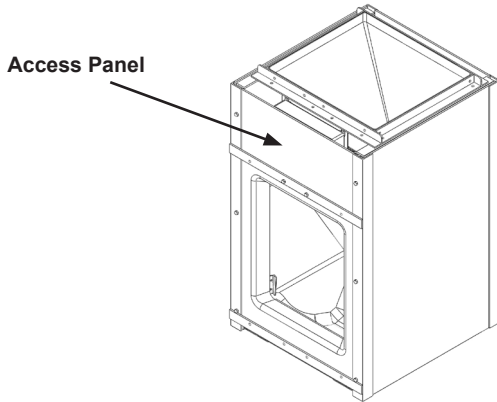

2. Remove the two (2) 5/16 x 1-in. bolts and wiz nuts at the top of the front panel and remove the panel. The bolts will not be used and may be discarded. However, **keep the wiz nuts** as they will be used later in the assembly process.

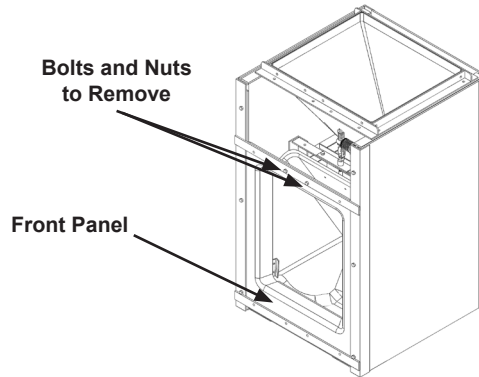

3. Attach one Race Adjust Angle to the feeder using two (2) 5/16 x 7/8-in. bolts, lock washers, and hex nuts. Ensure the holes in the Adjust Angle are toward the **top** of the feeder. Fasten the angle to the feeder by inserting the bolts through the feeder and then through the Adjust Angle on the two (2) **outside** holes. **NOTE: Bolt heads must be on the feeder side. DO NOT TIGHTEN.**

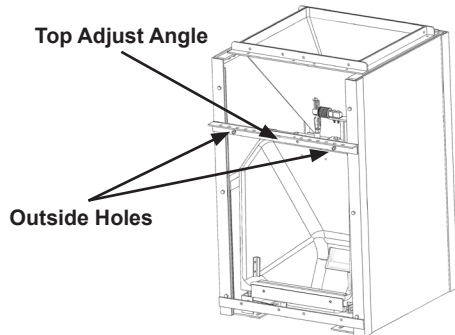

4. Attach another Race Adjust Angle to the feeder using two (2) 5/16 x 7/8-in. bolts, lock washers, and hex nuts. Fasten the Angle in the same manner as the previous step, again, through the outside holes. Ensure the holes in the Adjust Angle are toward the **bottom** of the feeder. **NOTE: Bolt heads must be on the feeder side. DO NOT TIGHTEN.**

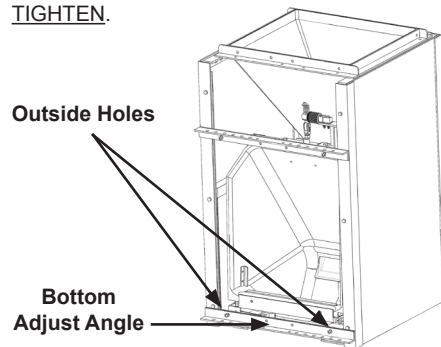

5. Re-install the front panel with the two (2) 5/16 x 1 1/2-in. bolts and existing wiz nuts.

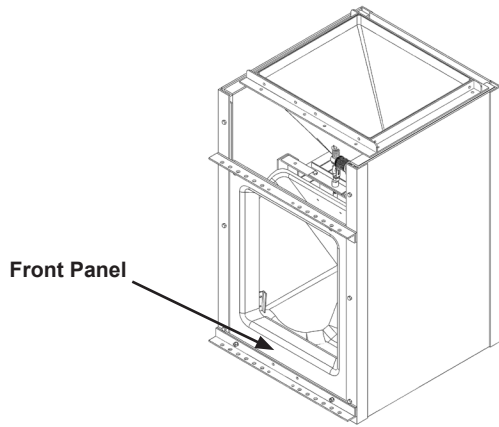

6. Stand the Long Race End Frame to support the Long Race Bar and fasten at both ends using the remaining four (4) 5/16 x 7/8-in. bolts, lock washers, and nuts. **DO NOT TIGHTEN.**

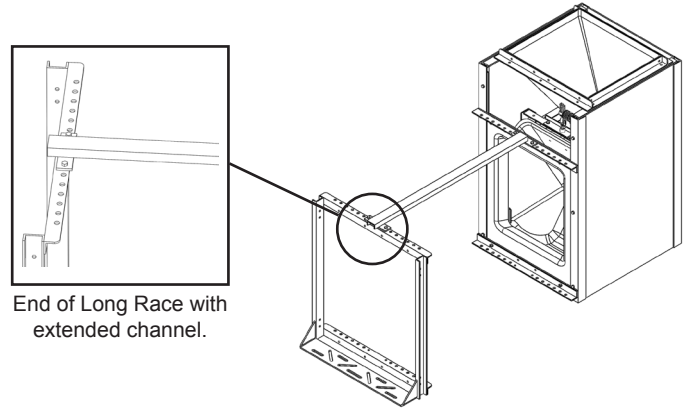

7. Install the two (2) Long Race Panels toward the outer sides of the Adjust Angles and End Frame. Secure using the Drop Pins.

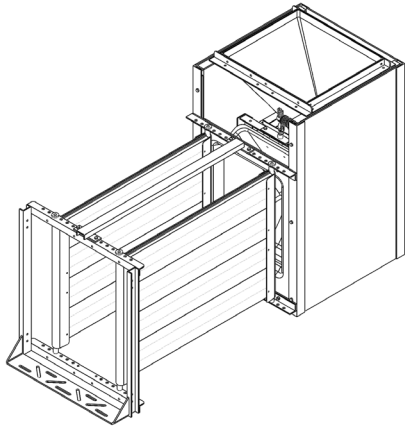

8. Install the IFC enclosure to the top of the feeder, replace the small black access panel, and **tighten all fasteners**. The completed assembly should appear similar to the drawing below.

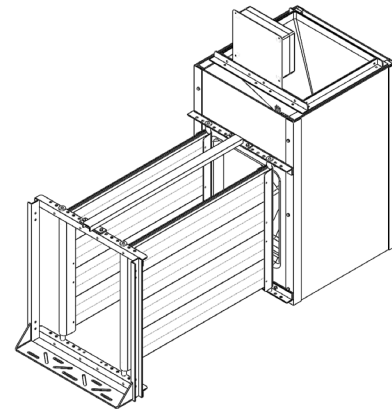

1-785-346-2192 · 1-800-255-0316

sales@osborne-ind.com · www.osbornelivestockequipment.com